

CARGO SECURING INSTRUCTION

ROAD TRANSPORT - MACHINE LOADED WITH THE FRONT FORWARD

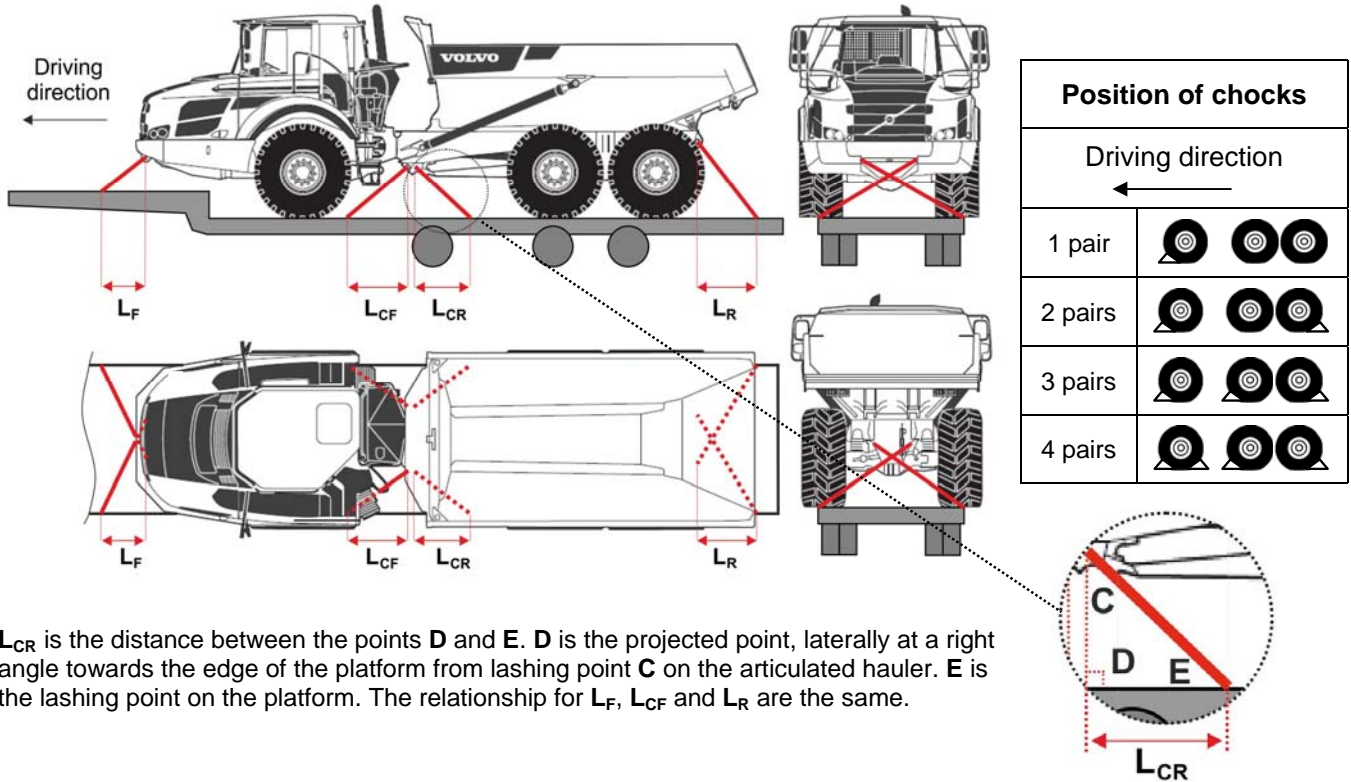

Friction surfaces		Chocks or blocking ¹		Permissible distance intervals of the lashings in metres							
				Chain min. class 8 Ø10 mm MBL 12 tonnes, LC 60 kN (6 tonnes)				Chain min. class 8 Ø13 mm MBL 20 tonnes, LC 100 kN (10 tonnes)			
				L_F (cross)	L_{CF}	L_{CR}	L_R (cross)	L_F (cross)	L_{CF}	L_{CR}	L_R (cross)
Rubber, pine, birch with rubber friction pad (clean and dry or wet) $\mu = 0.5$	Chocks	None	Not permitted alternative				1.0 – 3.0	Not necessary	0.8 – 1.8	1.5 – 3.0	
		1 pair	1.1 – 3.0	0.4 – 1.0	0.8 – 1.8	1.5 – 3.0	1.0 – 3.0	Not necessary	0.4 – 1.8	0.9 – 3.0	
		2 pairs	0.3 – 3.0	Not necessary	0.8 – 1.8	1.5 – 3.0	0.3 – 3.0	Not necessary	0.4 – 1.8	0.9 – 3.0	
		3 pairs	0.3 – 3.0	Not necessary	Not necessary	0.9 – 3.0	0.3 – 3.0	Not necessary	Not necessary	0.5 – 3.0	
	4 pairs										
	Blocking	Forward (Fwd)	1.1 – 3.0	0.4 – 1.0	Not necessary	0.3 – 3.0	1.0 – 3.0	Not necessary	Not necessary	0.3 – 3.0	
		Sideways (Sw)	Not permitted alternative				1.0 – 3.0	Not necessary	0.8 – 1.8	1.5 – 3.0	
Fwd & Sw		1.1 – 3.0	0.4 – 1.0	Not necessary	0.3 – 3.0	1.0 – 3.0	Not necessary	Not necessary	0.3 – 3.0		
Frost, ice, snow, mud, birch without rubber friction pad $\mu = 0.2$	Chocks	None	No permitted alternatives				1.2 – 3.0	0.2 – 1.0	0.9 – 1.8	1.9 – 3.0	
		1 pair					1.2 – 3.0	0.2 – 1.0	0.5 – 1.8	1.1 – 3.0	
		2 pairs	0.4 – 3.0	0.0 – 1.0	1.2 – 1.8	1.9 – 3.0	0.3 – 3.0	Not necessary	0.5 – 1.8	1.1 – 3.0	
		3 pairs	0.4 – 3.0	0.0 – 1.0	0.3 – 1.8	0.9 – 3.0	0.3 – 3.0	Not necessary	0.2 – 1.8	0.5 – 3.0	
	4 pairs	0.3 – 3.0	0.0 – 1.0	0.3 – 1.8	0.9 – 3.0						
	Blocking	Forward (Fwd)					1.2 – 3.0	0.2 – 1.0	Not necessary	0.3 – 3.0	
		Sideways (Sw)	No permitted alternatives				1.2 – 3.0	0.2 – 1.0	0.9 – 1.8	1.9 – 3.0	
Fwd & Sw						1.2 – 3.0	0.2 – 1.0	Not necessary	0.3 – 3.0		

1) Please see page 3, no 22 – 25, for detailed instructions

The instructions are valid when the conditions on page 3 are met

CARGO SECURING INSTRUCTION

ROAD TRANSPORT - MACHINE LOADED WITH THE BACK FORWARD

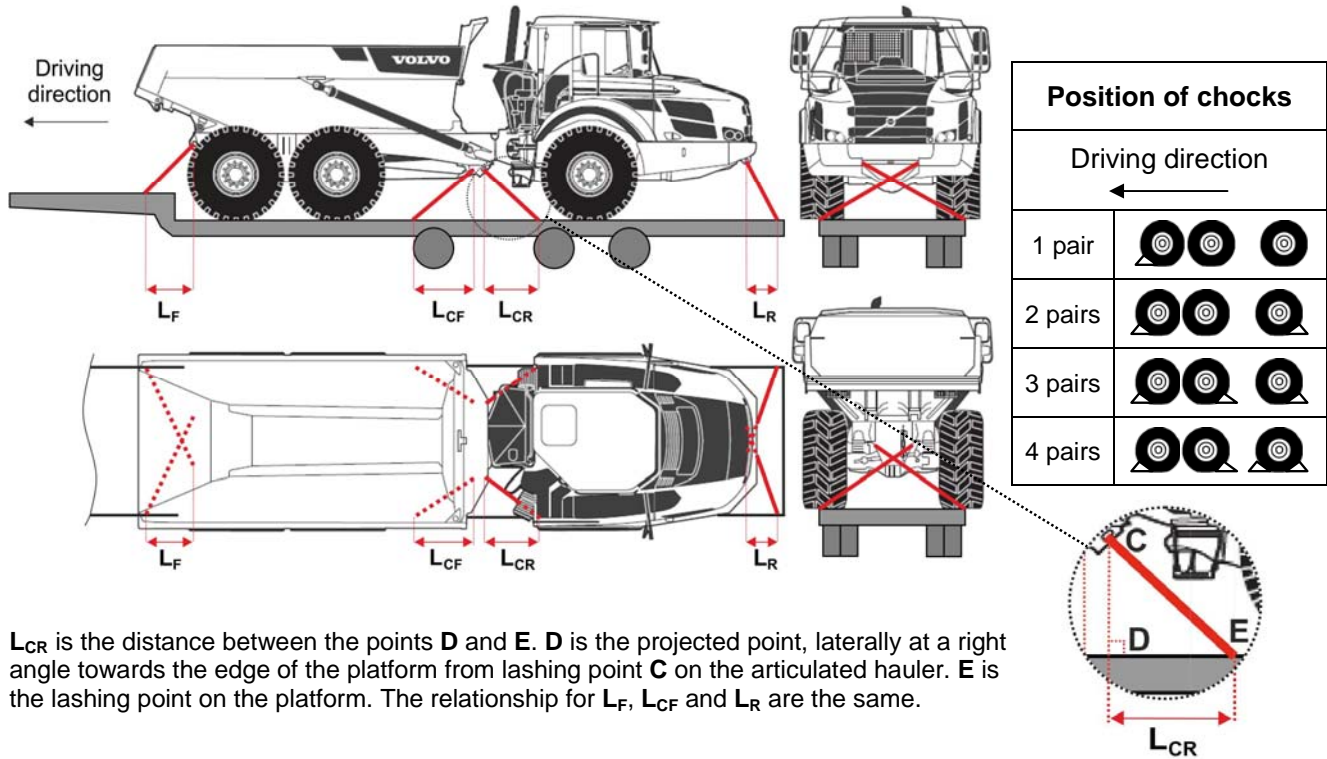

L_{CR} is the distance between the points D and E. D is the projected point, laterally at a right angle towards the edge of the platform from lashing point C on the articulated hauler. E is the lashing point on the platform. The relationship for L_F , L_{CF} and L_R are the same.

Friction surfaces		Chocks or blocking ¹⁾		Permissible distance intervals of the lashings in metres							
				Chain min. class 8 Ø10 mm MBL 12 tonnes, LC 60 kN (6 tonnes)				Chain min. class 8 Ø13 mm MBL 20 tonnes, LC 100 kN (10 tonnes)			
				L_F (cross)	L_{CF}	L_{CR}	L_R (cross)	L_F (cross)	L_{CF}	L_{CR}	L_R (cross)
Rubber, pine, birch with rubber friction pad (clean and dry or wet) $\mu = 0.5$	Chocks	None	No permitted alternatives				Not permitted alternative				
		1 pair	No permitted alternatives				1.1 – 3.0	Not necessary	0.2 – 1.0	1.2 – 3.0	
		2 pairs	No permitted alternatives				0.3 – 3.0	Not necessary	0.2 – 1.0	1.2 – 3.0	
		3 pairs	0.3 – 3.0	Not necessary	Not necessary	0.8 – 3.0	0.3 – 3.0	Not necessary	Not necessary	0.5 – 3.0	
	4 pairs	0.3 – 3.0	Not necessary	Not necessary	0.8 – 3.0	0.3 – 3.0	Not necessary	Not necessary	0.5 – 3.0		
	Blocking	Forward (Fwd)	1.0 – 3.0	0.5 – 1.8	Not necessary	0.3 – 3.0	1.1 – 3.0	Not necessary	Not necessary	0.3 – 3.0	
		Sideways (Sw)	Not permitted alternative				Not permitted alternative				
Fwd & Sw		1.0 – 3.0	0.5 – 1.8	Not necessary	0.3 – 3.0	1.1 – 3.0	Not necessary	Not necessary	0.3 – 3.0		
Frost, ice, snow, mud, birch without rubber friction pad $\mu = 0.2$	Chocks	None	No permitted alternatives				Not permitted alternative				
		1 pair	No permitted alternatives				1.0 – 3.0	0.3 – 1.8	0.4 – 1.0	1.2 – 3.0	
		2 pairs	No permitted alternatives				0.3 – 3.0	Not necessary	0.4 – 1.0	1.2 – 3.0	
		3 pairs	0.4 – 3.0	0.0 – 1.8	0.2 – 1.0	1.1 – 3.0	0.3 – 3.0	Not necessary	0.2 – 1.0	0.5 – 3.0	
	4 pairs	0.3 – 3.0	0.0 – 1.8	0.2 – 1.0	1.1 – 3.0						
	Blocking	Forward (Fwd)	1.6 – 3.0	0.7 – 1.8	0.0 – 1.0	0.3 – 3.0	1.0 – 3.0	0.3 – 1.8	Not necessary	0.3 – 3.0	
		Sideways (Sw)	Not permitted alternative				Not permitted alternative				
Fwd & Sw		1.6 – 3.0	0.7 – 1.8	0.0 – 1.0	0.3 – 3.0	1.0 – 3.0	0.3 – 1.8	Not necessary	0.3 – 3.0		

1) Please see page 3, no 22 – 25, for detailed instructions

The instructions are valid when the conditions on page 3 are met

CARGO SECURING INSTRUCTION

The instructions are valid for Volvo articulated hauler model A25F and A30F when the following conditions are met:

Design acceleration data

1. The hauler is subjected to max accelerations of; 0.8 g forward, 0.5 g rearward, 0.5 g sideways and 0.2 g upward.
2. The accelerations forward, rearward and sideways are acting individually and they are combined with 1 g downward.
3. The upward acceleration is not combined with other accelerations.
4. (A safety factor of 1.25 has been used to take account for uneven distribution of forces in the lashings. The arrangement can also withstand an acceleration of 1 g forward without safety factor.)

National requirements

5. The above design acceleration data fulfil the basic requirements in almost all road regulations and standards. However, in some countries national rules and guidelines may require alternative or additional blocking and / or lashing.

Articulated hauler data

6. The hauler (with or without fitted equipment) is from Volvo Construction Equipment.
7. The weight of the hauler does not exceed 28,000 kg.
8. The hauler has new or normally worn rubber wheels or wood-fitted rims of pine or birch. If the wood-fitted rims comprise of birch wood, a rubber friction pad must be placed between the wood surface of the rim and the platform to achieve a friction level of 0.5, else the friction level is assumed to be 0.2 only.

Loading and securing on transport carrier

9. The hauler is positioned laterally centred (± 5 cm) with the support of at least half of the width of the tyres.
10. The parking brake is applied and in working order and able to keep the hauler stationary on inclines up to 14° (25 %).
11. The steering joint lock is applied.
12. The hauler is loaded and secured in such a way that no parts such as painted surfaces and tyres are damaged.

Transport carrier

13. The hauler is loaded on a vehicle with a platform of wood, plywood, grooved aluminium or unpainted or painted steel.
14. The lateral distance between the lashing attachments on the vehicle is about 2500 mm.
15. The lashing attachments on the trailer have at least the same breaking load as the lashings.

Lashings

16. The lashings are tensioned to at least 4000 N (400 kg) during the entire transport.
17. The lashings are placed symmetrically, in pairs and are fixed to the designated lashing points on the hauler. Only one lashing shall be attached to each lashing point on the transport vehicle.
18. It should not be possible for the lashing hooks to come loose if the lashing becomes slack.
19. The maximum securing load (MSL/LC/SWL) of the chain is at least 50 % of the minimum breaking load (MBL).
20. When short and vertical lashings are used, on machines fitted with rubber tyres, shock absorbers should be used to reduce the risk of jerks in the lashings.
21. If chain lashings with different strength are used the instructions for the chain with the lowest strength are to be applied.

If chocks or blocking is used the following conditions shall be met:

22. The chocks are; firmly attached, have an angle of inclination of 37° (3:4:5), are at least 25 cm in height and are placed in pairs, 1, 2, 3 or 4 pairs according to the table indicating the position of chocks.
23. If rubber wheels or wood-fitted rims are supported by wheel grooves, these may be considered to be the equivalent of chocks.
24. Blocking of the rear of the articulated hauler or the wheel pairs turned in driving direction up to at least the wheel radius against goose-neck or corresponding in forward direction prevents forward movements.
25. Blocking with adequate height acting on the inside or outside of the wheels prevents sideways movements.

These instructions have been worked out by:

Volvo Construction Equipment AB
Global Laws & Regulations
Dept. 74200, TCA 11
SE-631 85 Eskilstuna, Sweden
www.volvo.com

MariTerm AB
P.O. Box 74
SE-263 21 Höganäs, Sweden
info@mariterm.se
www.mariterm.se