

## REQUIREMENTS FOR ROAD TRANSPORTATION OF CONSTRUCTION EQUIPMENT

- 1** Introduction
- 2** General requirements
- 3** Loading/unloading operation
- 4** Lashing/securing on carrier
- 5** Driving manual for Wheel loaders
- 6** Driving manual for Excavators
- 7** Driving manual for Backhoe loaders
- 8** Driving manual for Articulated Haulers
- 9** Driving manual for Motor Graders
- 10** Damages
- 11** Audits



## 1

## INTRODUCTION

These requirements are valid for all kind of road transports of Volvo Construction Equipment.

These requirements are Volvo's minimum demands on all involved road transporters as well as for subcontractors.

Each transport company can issue its own requirements, but these must be in accordance with Volvo's. If the transport company produces its own instructions, a copy must be sent to Volvo Logistics Corp.

Please note that these requirements do not in any way supersede the regulations stipulated by various authorities.

Random inspections and planned audits will be made continuously within areas where loading/unloading takes place.

Detected remarks will be reported to the person responsible at the transport company or contract holder.

The transport companies are responsible for ensuring that all drivers involved have good knowledge regarding these requirements.

All product training for personnel should be rated in writing. These training records must be maintained and updated, and to be handed over to Volvo Logistics upon request.

The handling instruction provided by VLC has improved and will also be updated on an ongoing basis. Please contact Volvo Logistics Dept 7140 for the latest edition available.

### **VOLVO LOGISTICS CORPORATION**

Risk Management Department  
<http://web.volvo.com/vlc>

Catelijan Stefan  
<mailto:stefan.catelijan@volvo.com>

Jonas Svensson  
<mailto:jonas.svensson@volvo.com>

Phone: + 32 9 250 3807  
Fax: + 32 9 259 2603

Phone: + 46 31 669315  
Fax: + 46 31 547123

## **2 GENERAL REQUIREMENTS**

### **2.1 Parking areas and roadways**

#### **2.1.1 General condition**

All parking areas and roadways:

- must be well separated from other activities
- must be free from any object that may damage the machines
- must be cleaned up regularly
- must be fenced, guarded and lighted
- should be covered with hard surface

The machines should be parked away from sources of emission that could contaminate them.

#### **2.1.2 Slippery prevention**

Avoid using salt for slippery prevention. Loading/unloading areas, requiring slippery prevention, must have valid and updated routines for this. Used slippery prevention material must be cleaned up as soon as the weather allows it.

#### **2.1.3 Snow and ice**

Snow on parking areas must be removed before the machines are parked. Snow to be taken away with proper equipment. Rotating brushes or snow thrower are not to be used close to the machines.

#### **2.1.4 Parked machines**

When machines are parked make sure that:

- The machine does not freeze to the ground, sink or suffer any other consequences
- Bucket is lowered to the ground (Excavators, Wheel loaders, Backhoe loaders)
- Parking brake in on-position
- Switches and operating controls are switched in off/neutral position
- Safety locking system is secured (Excavators)
- Wiper blades in rest position

- All windows, doors etc. are closed/locked
- Key in the ignition or according to respective yards/ports routine
- Electric main switches in off position\*
  
- \* Located near the fuel filler pipe, behind the back side grille (Wheel loaders)
- \* Located behind the maintenance flap, on the left side of the machine (Compact Wheel loaders)
- \* Located inside the tool box, on the right side of the machine (Excavators)
- \* Located inside the battery box, on the right side of the machine (Compact Excavators)
- \* Located outside the battery box on the left side of the machine (Backhoe loaders)
- \* Located during the entry step on the left side of the machine (Articulated Haulers)
- \* Located inside the engine compartment, on the left side of the machine (Motor Graders)

Park all machines as follows:



DRIVER'S DOOR SHOULD ALWAYS BE OPENED INTO AN OPEN SPACE.

## 2.1.5 Distances between parked machines

Minimum parking distances between **light machinery**:

- Between sides 50 cm (20 inches) measured between the most extreme part of the machine
- Between machines lengthwise 30 cm (12 inches)



Minimum parking distances between **heavy machinery**:

- Between sides 1 metre (40 inches) measured between the most extreme part of the machine
- Between machines lengthwise 30 cm (12 inches)



## 2.2 Carrier

### 2.2.1 General condition

**When transporting the machine, obey the related laws governing the weight, width, height, length and securing of the load.**

Parking brake of truck/trailer should be applied, and blocks should be inserted beneath the truck/trailer tires before loading/unloading.



It is not allowed that the tarpaulin of covered transports is in contact with the body parts of the machine during transport. This to prevent the body parts from scratches.

### 2.2.2 Ramps and loading platforms

Ramps and decks must be constructed in such a way that there is no risk of damaging the machines.

Make sure the ramps have the right strength, width, length and thickness.

All ramps and loading platforms must have rounded and soft approach and be at an angle of no more than 15 degrees.

All ramps and loading platforms must be regularly cleaned. Rust, grease, oil, mud or ice should be removed before starting any loading operation.

Retract all attachments and raise it in a free space from the ground.

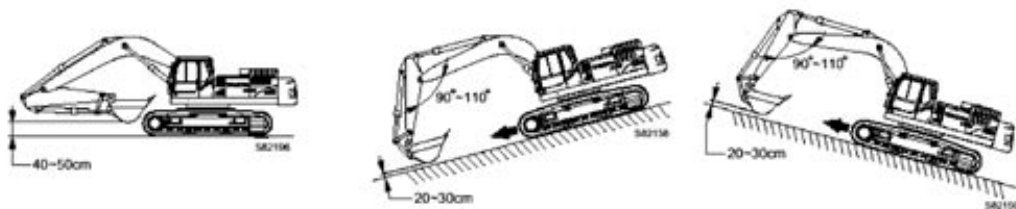

### 2.2.3 Dangerous areas

Make sure that all attachments are retracted when operating in confined areas as a covered trailer.

- \* Check if there is sufficient room for the machines
- \* Move slowly

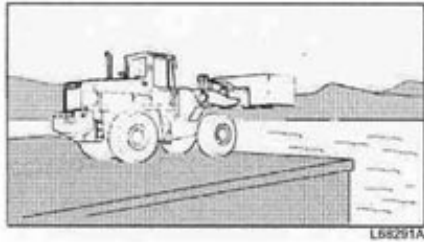

## Dangerous areas

- \* observe great care near marked danger areas.
- \* do not operate too close to the edge of a quay, ramp, etc.

## 2.2.3 Lashing/securing equipment

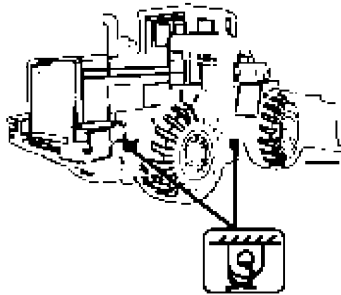

Lashing is only allowed on foreseen attaching points.

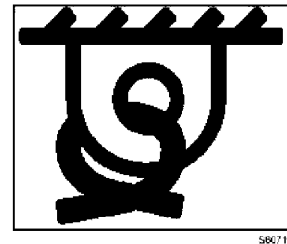

Towing the machine from these points is prohibited.

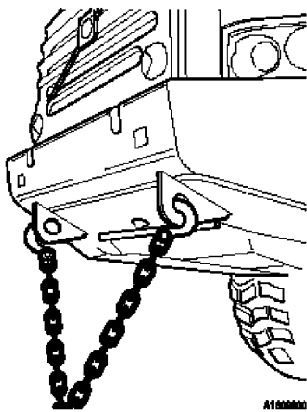

Hooks are never to be attached directly into the chassis.

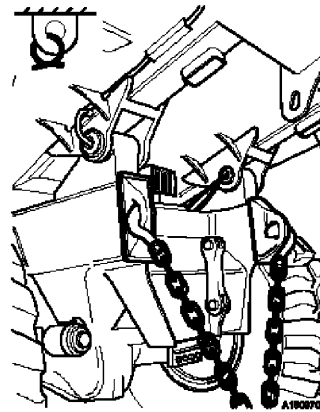

**It is not allowed to use soft slings during transport for securing the machinery.**

Fixed lashing equipment, such as floor chains and eyelets, should be designed and attached in such a way that they do not damage tyres or tracks.

## 3 LOADING/UNLOADING OPERATION

### 3.1 Preparation before operation starts

#### 3.1.1 Information to truck drivers

All truck drivers must have knowledge about these instructions.

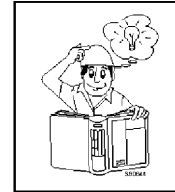

#### 3.1.2 Clothing

Clothes, gloves and shoes must be clean to avoid dirtying the machines interior.  
All buttons and zippers must be covered.  
No tools or similar in pockets.



#### 3.1.3 Miscellaneous

Eating, drinking and smoking inside or next to the machines is not allowed.

The machine only to be moved between parking areas and the carrier.  
Using the machines travelling to and from places to eat, for example, is strictly forbidden.

Passengers are not allowed inside, outside or nearby the machines.

Do not turn on audio- or other unnecessary equipment.

It is not allowed removing any protection from the machines.

#### 3.1.4 Drawing/marketing/dismounting

Writing on the vehicles with any material is forbidden, as well as attaching stickers to the machines painted surfaces.

Parts on **Excavators**, may only be dismantled when necessary and after approval from Volvo Construction Equipment delivery department.

Dismounting of parts on **Light Machinery, Wheel loaders, Backhoe loaders, Articulated Haulers** and **Motor Graders** are not allowed.

## 3.1.5 Damage inspection

Check for damages before entering the machines. If a damage is found **see chapter 10**.

## 3.1.6 Preparation of carrier

The following items should be checked before loading/unloading operation starts (**See chapter “ 2.2 Carrier “**)

- All roadways, ramps and loading platforms should be free from lashings and other material that could cause damage to the machines.
- All ramps and loading platforms must be adjusted to fit the measurements of the machines.

## 3.1.7 Snow and ice

Snow and ice on the machine windows must be removed. Snow to be taken away with a soft brush. Use only ice scraper with a plastic edge.

## 3.2 Loading/unloading onto/from carrier

### 3.2.1 Driving routines for the different machines

See **“Driving manual for wheel loaders”** in chapter 5.

See **“Driving manual for excavators”** in chapter 6.

See **“Driving manual for backhoe loaders”** in chapter 7.

See **“Driving manual for articulated haulers”** in chapter 8.

See **“Driving manual for motor graders”** in chapter 9.

### 3.2.2 Tow/jump start

It is absolutely forbidden to use the machines for towing and to jump-start other vehicles. If the battery is low, use a battery from a service car.

## 3.2.3 Speed limits

Maximum speed limit for machines on tyres is 10 km/hour (6miles/hour).  
Maximum speed limit for machines on tracks is 5 km/hour (3 miles/hour).  
Maximum speed limit for machines on woodblocks is 5 km/hour (3 miles/hour).

**Maximum speed limit when using sand or stone chips for slippery prevention 5 km/hour (3 miles/hour). Keep extra long distance between machines to avoid stone chipping.**

Safe and calm driving is the policy.

## 3.2.4 Clearance

Minimum clearance between chassis and carrier during loading/unloading operation must be according the local "Risk Management" representative's instructions.

## 3.3 Parking on carrier

### 3.3.1 Loaded vehicles

Following applies to parked machines:

- Bucket is lowered to the ground (Excavators, Wheel loaders, Backhoe loaders)
- Parking brake in on-position
- Switches and operating controls are switched in off/neutral position
- **Safety locking system is secured**

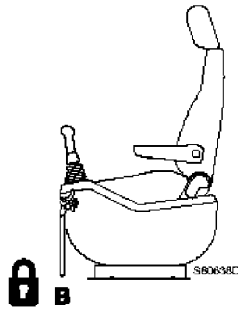

Safety lock for:  
excavators



Safety lock for:  
articulated haulers  
motor graders  
wheel loaders

- Wiper blades in rest position
- All windows, doors etc. are closed/locked
- Key in the ignition or according to respective yards/ports routine
- Electric main switches in off position\*
  
- \* Located near the fuel filler pipe, behind the back side grille (Wheel loaders)
- \* Located behind the maintenance flap, on the left side of the machine (Compact Wheel loaders)
- \* Located inside the tool box, on the right side of the machine (Excavators)
- \* Located inside the battery box, on the right side of the machine (Compact Excavators)
- \* Located outside the battery box on the left side of the machine (Backhoe loaders)
- \* Located during the entry step on the left side of the machine (Articulated Haulers)
- \* Located inside the engine compartment, on the left side of the machine (Motor Graders)

Never park machines with their wheels/tracks upon floor chains, fixed lashing eyelets or any other objects.

All machines must be locked if the carrier is left without supervision during the transport.

## 3.3.2 Distances between parked vehicles

Minimum distances

- Between machines lengthwise 20 cm (8 inches).



**It is not allowed that the tarpaulin of covered transports is in contact with the body parts of the machine during transport. In this case approved protection material can be used.**

The driver must always be able to open the driver's door into an open space.

**3.4 If a damage is caused during loading/unloading operation, see chapter 10.**

## **4 LASHING ONBOARD CARRIER**

### **4.1 Lashing/unlashing routine**

There are different regulations depending on the country in which the transport takes place.

The general rule is that all machines must be secured on the carrier. The securing must be done by a combination of wheel chocks and lashings (or tie-down, if applicable).

It is the transporters responsibility to make sure that they are following the respective country's legal regulations and that loaded machines can not move during transport.

### **4.2 Lashing/securing of construction equipment**

#### **4.2.1 Lashing/securing preparation**

Before starting any lashing operation, make sure all safety-locking systems are secured.

- \* Wheel loaders are foreseen of a steering joint lock.



**Steering joint lock**

- \* Excavators are foreseen of a safety lock.



**Safety lock ON**



**Safety lock OFF**

- \* Articulated haulers are foreseen of a steering joint lock.



**Steering joint lock**

- \* Motor graders are foreseen of two articulation lock pins.



**Articulation lock pins**

**Make sure that at least each machine is foreseen of 4 wheel chocks during transport.**

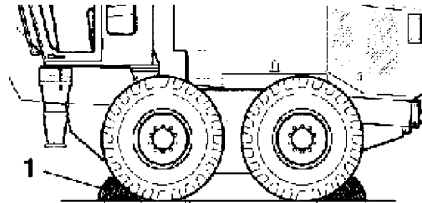

1 Wheel chocks

00005173

Tie down the machine on the foreseen anchoring lugs. Hooks are never to be attached directly into the chassis. Soft sling never can be used during transport, to secure the machine.



## 4.2.2 Lashing methods

There are different methods to lash/tie down Volvo Construction Equipment depending on the model.

### Lashing method for Wheel loaders



### Lashing method for Excavators

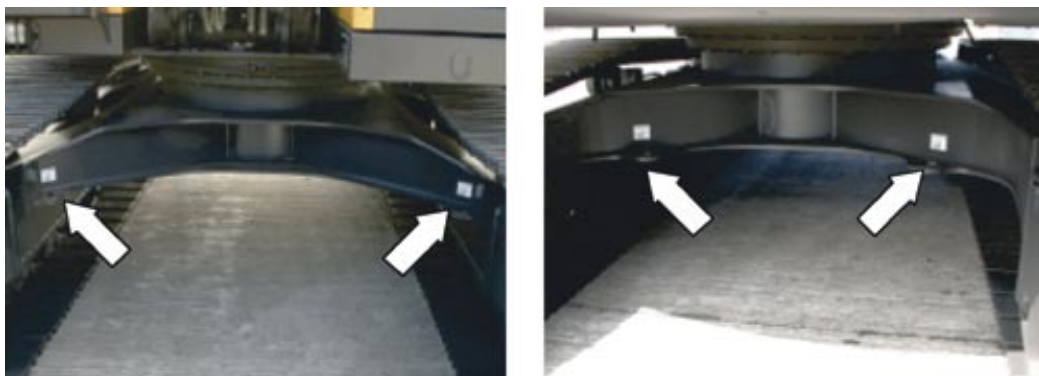

## Lashing method for Backhoe loaders



## Lashing method for Articulated Haulers

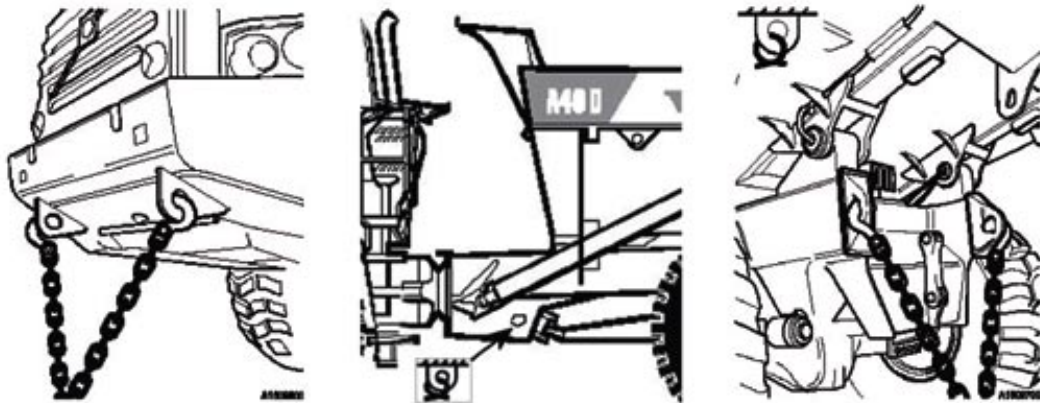

## Lashing method for Motor Graders

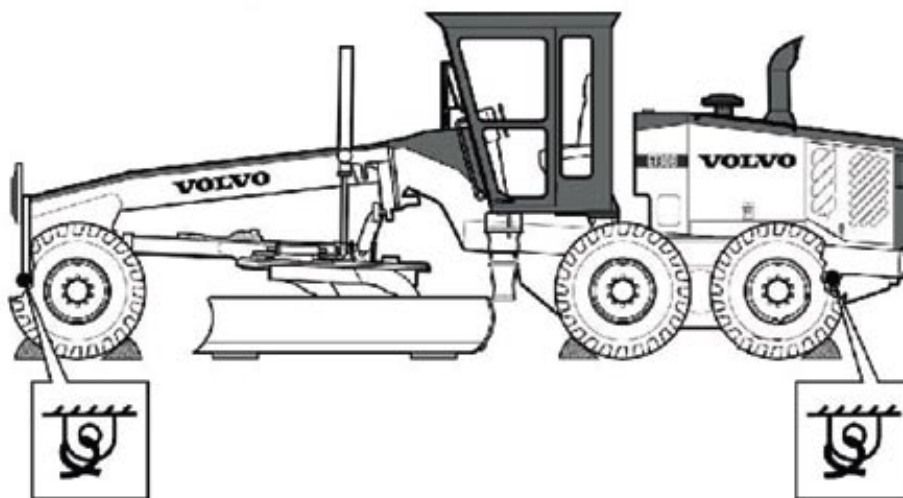

## 4.2.3 Attachment of lashing sling

Always consult the “Cargo Securing Certificate” to attach the lashing slings in the correct way. Each machine is foreseen of this certificate when leaving the factory.

Keep in mind that lashings never make contact with the chassis.

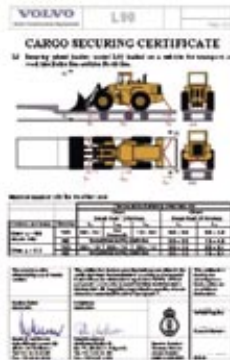

## 5 DRIVING MANUAL FOR WHEEL LOADERS

### 5.1 Starting Wheel loaders.

1. Remove the steering joint lock if secured  
(**See chapter “ 4.2.1 Lashing/securing preparation “**).
2. Turn on the electric main switch  
(**See chapter “ 2.1.4 Parked machines “**).
3. Bring gear selector in neutral position.

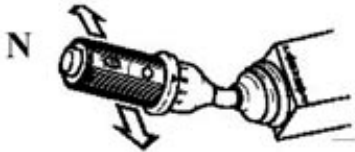

4. Start engine.

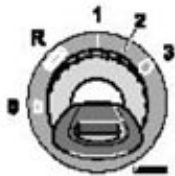

5. Release parking brake. Control lamp will extinguish.

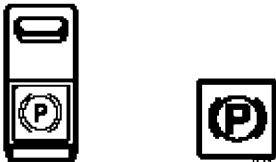

6. Raise bucket to drive freely.

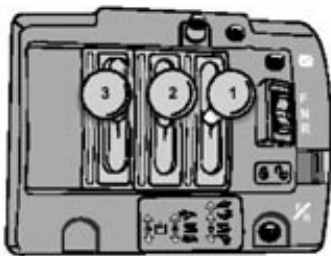

7. Bring gear selector in Forward or Reverse depending of the direction.



8. Press gas pedal to drive.

## 5.2 Stopping Wheel loaders

1. Release gas pedal
2. Push brake pedal
3. Bring gear selector in neutral position.



4. Apply parking brake. Control lamp lights up.



5. Lower bucket to the ground.
6. Turn off ignition.

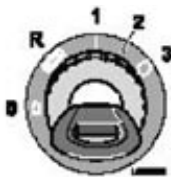

7. Turn off the electric main switch  
(**See chapter “ 2.1.4 Parked machines “**).
8. In case of transportation, make sure the steering joint lock is secured  
(**See chapter “ 4.2.1 Lashing/securing preparation “**).

## 6 DRIVING MANUAL FOR EXCAVATORS

### 6.1 Starting Excavators

1. Turn on the electric main switch  
(See chapter " 2.1.4 Parked machines ").
2. Turn off the safety lock  
(See chapter " 4.2.1 Lashing/securing preparation ").
3. Start engine.

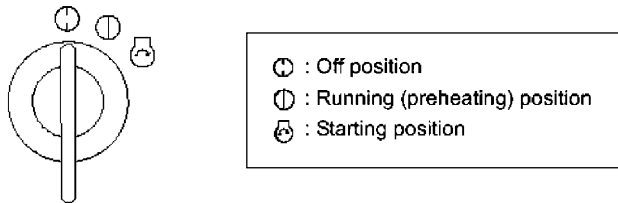

4. Raise bucket to drive freely.

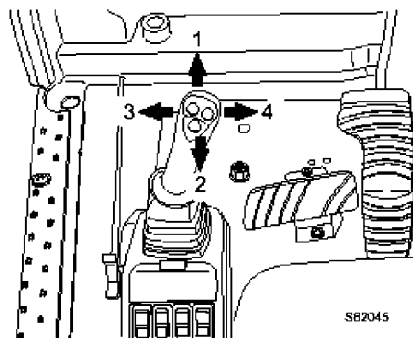

#### Operating lever (left):

- 1 Arm out
- 2 Arm in
- 3 Left swing
- 4 Right swing

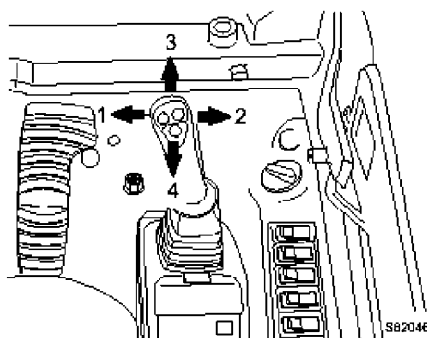

#### Operating lever (right):

- 1 Bucket in
- 2 Bucket out
- 3 Boom lower
- 4 Boom raise

5. Move lever/pedal to drive the machine forward or backwards.

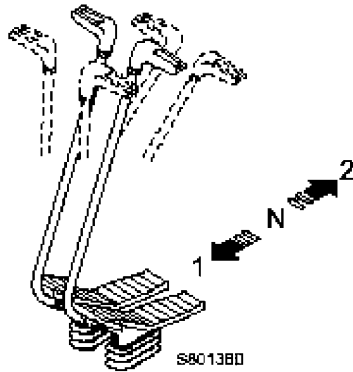

**N Neutral** position

**1 Forward**

Push the lever forward or press down on the pedal forward to advance the machine.

**2 Reverse**

Push the lever backward or press down on the pedal backward to reverse the machine.

6. Move lever/pedal to turn the machine left or right.

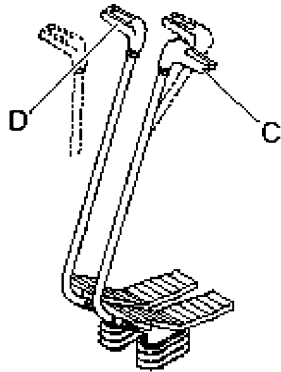

Push D forward: machine travels forward as it turns to the left.

Pull C backward: machine travels backward as it turn to the left.

Push C forward: machine travels forward as it turns to the right.

Pull D backward: machine travels backward as it turns to the right.

Operating C and D together in opposite direction gives a quick turn.

## 6.2 Stopping Excavators

1. Bring lever/pedal in neutral position.
2. Lower bucket to the ground.
3. Turn off ignition.

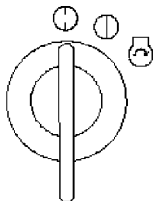

⊘ : Off position  
⚡ : Running (preheating) position  
🔑 : Starting position

4. Turn on the safety lock  
(**See chapter “ 4.2.1 Lashing/securing preparation “**).
5. Turn off the electric main switch  
(**See chapter “ 2.1.4 Parked machines “**).

## 7 DRIVING MANUAL FOR BACKHOE LOADERS

### 7.1 Starting Backhoe loaders.

1. Turn on the electric main switch  
(**See chapter “ 2.1.4 Parked machines “**).
2. Bring forward/reverse lever in neutral position.



3. Bring gearshift lever in neutral position. Don't forget to use the de-clutch switch.

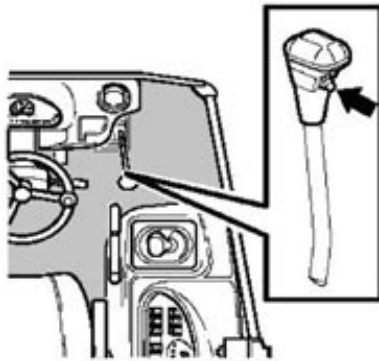

Transmission de-clutch switch

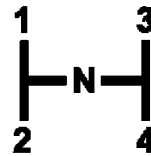

4. Start engine.

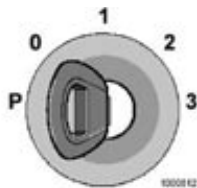

5. Release parking brake. Control lamp will extinguish.

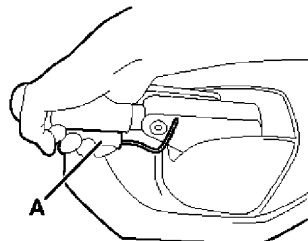

A Release catch

6. Raise front bucket to drive freely.

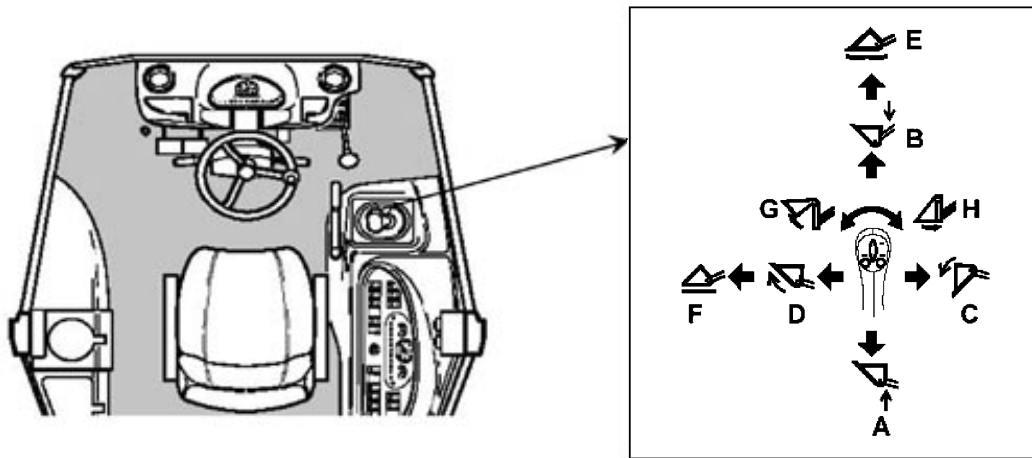

7. Bring gearshift lever in 1st gear. Don't forget to use the de-clutch switch.

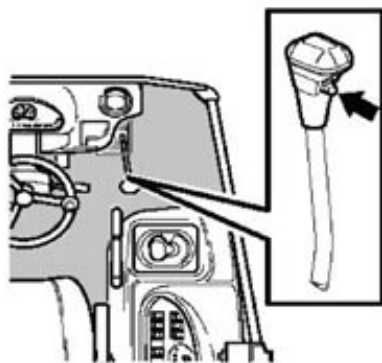

Transmission de-clutch switch

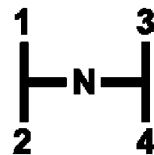

8. Bring lever in Forward or Reverse depending of the direction.



9. Press gas pedal to drive.

## 7.2 Stopping Backhoe loaders

1. Release gas pedal
2. Push brake pedal
3. Bring gearshift lever in neutral. Don't forget to use the de-clutch switch.

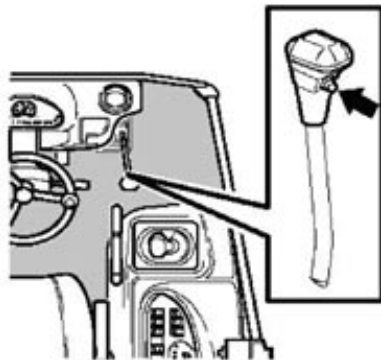

Transmission de-clutch switch

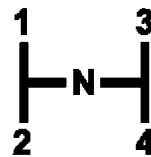

4. Bring gear selector in neutral position.

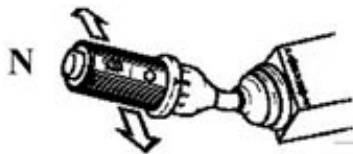

10. Apply parking brake. Control lamp lights up.

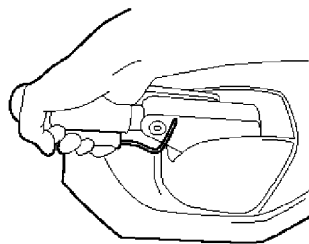

5. Turn off ignition.

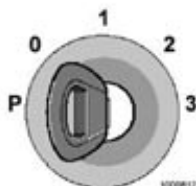

6. Turn off the electric main switch  
(**See chapter " 2.1.4 Parked machines "**).

## 8 DRIVING MANUAL FOR ARTICULATED HAULERS

### 8.1 Starting Articulated haulers

1. Remove the steering joint lock if secured  
(**See chapter “ 4.2.1 Lashing/securing preparation “**).
2. Turn on the electric main switch  
(**See chapter “ 2.1.4 Parked machines “**).
3. Bring gear selector in neutral position.

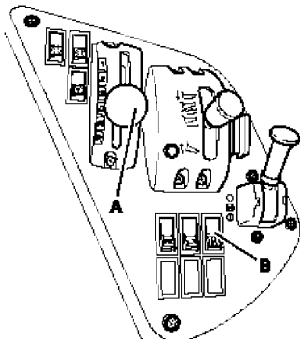

**A** Gear Selector

4. Start engine.

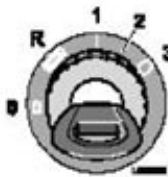

5. Release parking brake. Control lamp will extinguish.

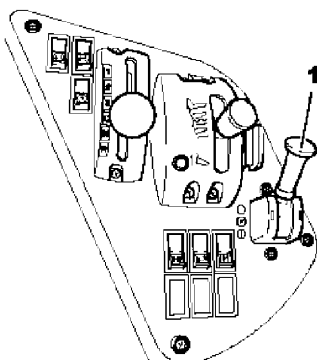

**1** Parking brake

6. Bring gear selector in Forward or Reverse depending of the direction.

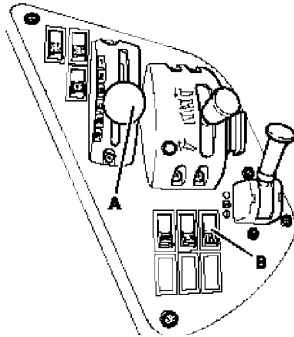

- A** Gear Selector
- B** High/Low gear

7. Press gas pedal to drive.

## 8.2 Stopping Articulated haulers

1. Release gas pedal
2. Push brake pedal
3. Bring gear selector in neutral position.

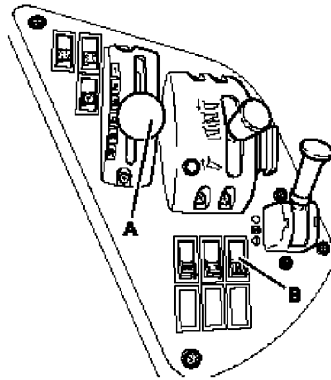

- A** Gear Selector

4. Apply parking brake. Control lamp lights up.

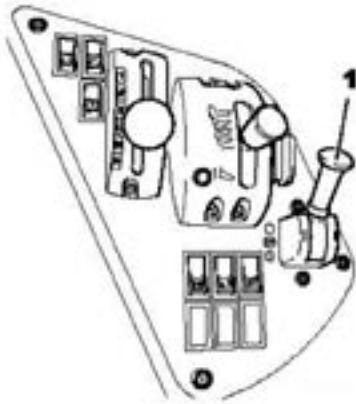

**1** Parking brake

5. Turn off ignition.

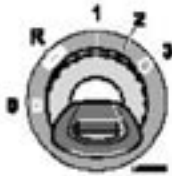

6. Turn off the electric main switch  
(**See chapter “ 2.1.4 Parked machines “**).
7. In case of transportation, make sure the steering joint lock is secured  
(**See chapter “ 4.2.1 Lashing/securing preparation “**).

## 9

## DRIVING MANUAL FOR MOTOR GRADERS

### 9.1 Starting Motor graders

1. Remove the articulation lock pins if secured  
(**See chapter “ 4.2.1 Lashing/securing preparation “**).
2. Turn on the electric main switch  
(**See chapter “ 2.1.4 Parked machines “**).
3. Bring gear selector in neutral position. Don't forget to use the clutch pedal.



4. Start engine.



5. Release parking brake. Control lamp will extinguish.

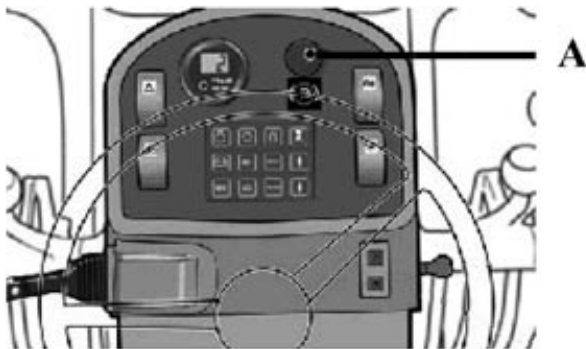

**A** Parking brake

6. Bring gear selector in Forward or Reverse depending of the direction. Don't forget to use the clutch pedal.



7. Press gas pedal to drive.

## 9.2 Stopping Motor graders

1. Release gas pedal
2. Push brake pedal
3. Bring gear selector in neutral position. Don't forget to use the clutch pedal.



4. Apply parking brake. Control lamp lights up.

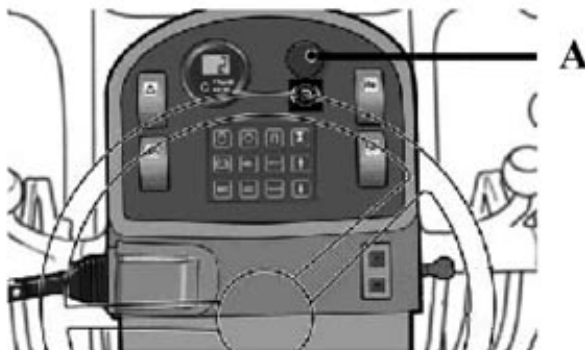

**A** Parking brake

5. Turn off ignition.



6. Turn off the electric main switch  
(**See chapter “ 2.1.4 Parked machines “**).
7. In case of transportation, make sure the articulation lock pins are secured  
(**See chapter “ 4.2.1 Lashing/securing preparation “**).

## **10 DAMAGES**

### **10.1 Avoid extended damages**

As a first action avoid extended damages.

Broken windows to be covered with plastic, remove loose hanging damaged parts, park the machine in a covered area and similar actions.

### **10.2 Reporting of damages/mechanical faults**

Always get in contact with Volvo Logistics if severe damages/mechanical faults are caused or detected.

Following must be reported:

- Type and chassis number
- Destination
- Type/extend of damage
- Who caused the damage
- Senders name, company, telephone number

### **10.3 Damage inspection**

The damage must be examined by Lloyd's surveyor, when the cost of repair is estimated to exceed:

USD	3 000
GBP	1 000
SEK	20 000
EUR	3 000

## 11 AUDITS

This audit form is to be used when inspectors from Volvo Logistics make random inspections or planned audits in ports and onboard ships.

**AUDIT "Name of the shipping line":** \_\_\_\_\_

Date : \_\_\_\_\_  
Port : \_\_\_\_\_  
Vessel : \_\_\_\_\_  
Voyage : \_\_\_\_\_  
Destination : \_\_\_\_\_  
No of units : \_\_\_\_\_

### LOADING/UNLOADING OPERATION

#### AUDIT FORM LOADING/UNLOADING ONTO/FROM SHIPS

#### DEMERIT POINTS

##### General requirements

2.1.1 - 3	Parking area and roadway condition	_____
2.1.4 - 5	Parking in port area	_____
2.2.1	Ships condition	_____
2.2.2	Construction of ramps and decks	_____
2.2.3	Lashing equipment	_____

##### Loading/unloading operation

3.1.1	Information to stevedores	_____
3.1.2	Clothing	_____
3.1.3	Miscellaneous	_____
3.1.4	Drawing/marketing/dismounting	_____
3.2.1	Driving routines for the different machines	_____
3.2.2	Tow/jump start	_____
3.2.3 - 4	Driving behaviour during loading/unloading	_____
3.3.1 - 2	Parking onboard ship (stowing)	_____

##### Lashing onboard ship

4.1	Lashing/unlashing routine	_____
4.2 - 3	Correct lashing method	_____

#### TOTAL DEMERIT POINTS

Demerit points: 0 = OK/No remarks  
1 = Minor remark without immediately effect on the quality of the machines  
2 = Major remark with immediately effect on the quality of the machines

#### REMARKS:

\_\_\_\_\_  
\_\_\_\_\_  
\_\_\_\_\_  
\_\_\_\_\_

