

### VEHICLE CONDITION REPORT

**MUST** be completed at time transit damage is identified.

Göteborg, Sweden

**1** Model

**2** Chassis

**3** Location Codes

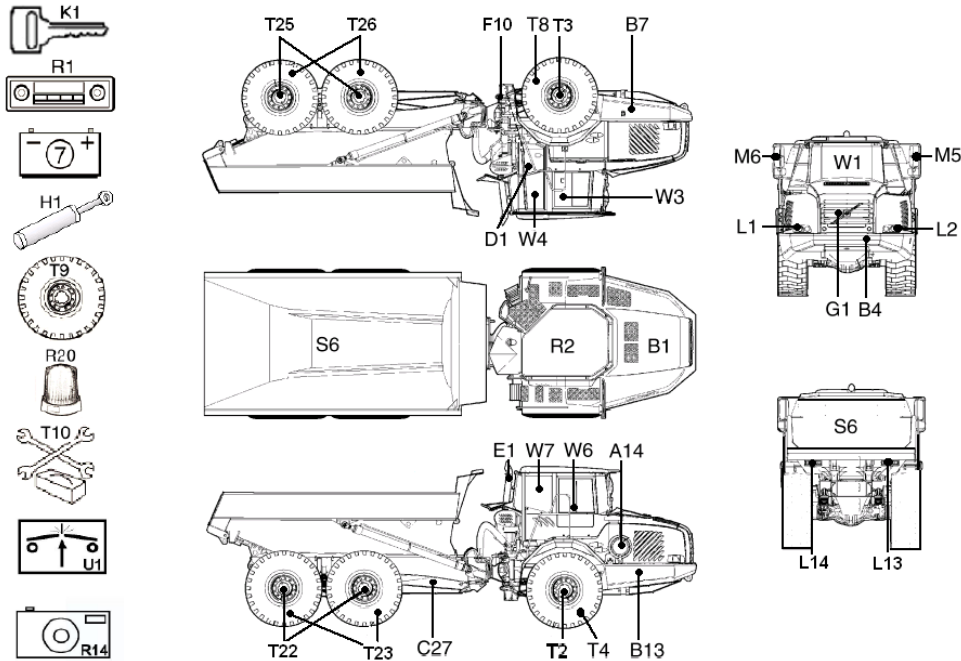

### 4 – Damage codes and descriptions

Code	GB	SE	DE	FR	IT	ES	NL
13	Puncture	Punktering	Reifenpanne	Percement Crevaision	Pneumatico forato	Perforación	Lekke band
27	Dent	Buckla	Beule	Bosse	Ammaccatura	Abolladura	Deuk
28	Scratch	Repa	Kratzer	Rayure	Graffio	Arañazo	Kras
29	Paint ship	Lackavslag	Lackspritzer	Défaut de peinture	Vernice Scheggiata	Pintura desportillada	Lakpunt
53	Missing	Saknas	Fehlteile	Manquant	Mancanze	Faltante	Ontbreekt
82	Broken	Avbruten	Abgebrochene Teile	Cassé	Rottura di pezzo	Roto	Stuk
99	Factory Fault	Produktionsfel	Werksfehler	Défaut usine	Difetto di Fabbricazione	Fallos de fábrica	Fabrieksfout

**5** – Location code

**6** – Damage code

**7** – Additional notes

		<p>.....</p> <p>.....</p> <p>.....</p>
--	--	--

### A 9 – HAND-OVER FROM

(a) Transport ref. (vessel name, truck reg, train code, plan nr)

(b) Company:

(c) Name:

(e) Signature & Stamp

(f) Date:

(g) City:



8 Company Type:

- |                          |              |  |              |                          |
|--------------------------|--------------|--|--------------|--------------------------|
| <input type="checkbox"/> | Factory      |  | Factory      | <input type="checkbox"/> |
| <input type="checkbox"/> | Air          |  | Air          | <input type="checkbox"/> |
| <input type="checkbox"/> | Road         |  | Road         | <input type="checkbox"/> |
| <input type="checkbox"/> | Distribution |  | Distribution | <input type="checkbox"/> |
| <input type="checkbox"/> | Rail         |  | Rail         | <input type="checkbox"/> |
| <input type="checkbox"/> | Body Builder |  | Body Builder | <input type="checkbox"/> |
| <input type="checkbox"/> | Sea          |  | Sea          | <input type="checkbox"/> |
| <input type="checkbox"/> | Retailer     |  | Retailer     | <input type="checkbox"/> |

### B 10 – HAND-OVER TO

(a) Transport ref. (vessel name, truck reg, train code, plan nr)

(b) Company:

(c) Name:

(e) Signature & Stamp

(f) Date:

(g) City:

### IMPORTANT

RESERVATIONS AT DELIVERY MUST APPEAR ON THE FREIGHT DOCUMENT PLEASE USE VCR (THIS DOCUMENT) AS A SUPPORT TO DETAIL NOTICED DAMAGES. TOP PAGE MUST STAY IN CHASSIS